



## 0-10V CO<sub>2</sub>, TEMP & HUMIDITY SENSOR

### TP-RS-CO2RHT FEATURES

- Modern, slimline design - only 19mm deep
- Accurate measurement of internal room temperature, humidity & CO<sub>2</sub>
- Polygiene® anti-microbial product protection
- Quick and simple installation

Featuring a sleek, modern and slimline design, the TP-RS-CO2RHT uses NDIR technology for CO<sub>2</sub> measuring and provides 0-10V signals for CO<sub>2</sub>, relative humidity and temperature conditions in the measured space and incorporates a second resistive 10K3A1 temperature output with other thermistor types available on request.

Incorporating automatic background calibration features, the CO<sub>2</sub> sensor is ideal for ventilation on demand applications where internal occupancy levels can vary throughout the working period such as in schools, offices, retail outlets, leisure facilities and theatres.

Quick release button, tamperproof features and pluggable terminals aid the install process and maintenance of the sensors.

All room housings within the Gen 3 product line incorporate certified Polygiene® product protection, designed to pro-actively inhibit the growth of bacteria on the sensor surface.

### SPECIFICATION

Material:	ABS (Flame retardant)
Supply:	24VAC/DC +/-10%
Power Consumption:	45mA
Outputs:	0-10V (0-2000ppm) 0-10V (0-100%RH) 0-10V (0-50°C) 10K3A1 Resistive
Accuracy:	CO <sub>2</sub> : 50ppm +/- 2% of reading Humidity: +/- 2%RH Temperature: +/- 0.2°C
CO <sub>2</sub> Sensing:	NDIR
IP Protection:	IP30
Mounting Location:	Wall mounted 1.5m from floor level
Environmental Conditions:	-10 to +60°C 0-95% RH Non-Condensing
Connections:	Pluggable screw terminals for 0.3 to 1.5mm cable
Recommended Cable:	Screened, twin twisted pair 0.75mm to 1mm. Screen earthed at controller end only.
Country of Origin:	UK
Product Codes:	TP-RS-CO2RHT-V-10K3



## CONNECTIONS

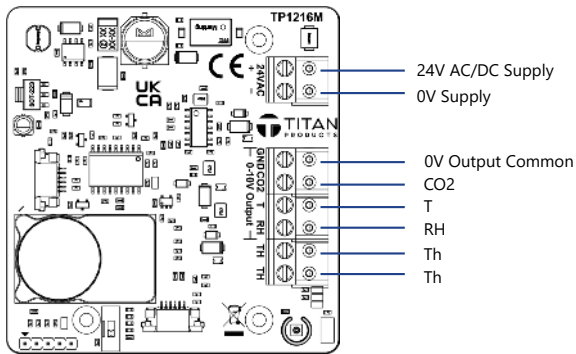

## CO2

### Automatic Background Calibration (ABC):

Titan CO2 sensors are supplied pre-calibrated and will auto calibrate every 7 days thereafter using automatic background calibration. To maintain calibration and long-term accuracy stability, the sensor should be exposed to low, unoccupied CO2 levels (typically 400ppm) at least once every 7 days.

## DIMENSIONS

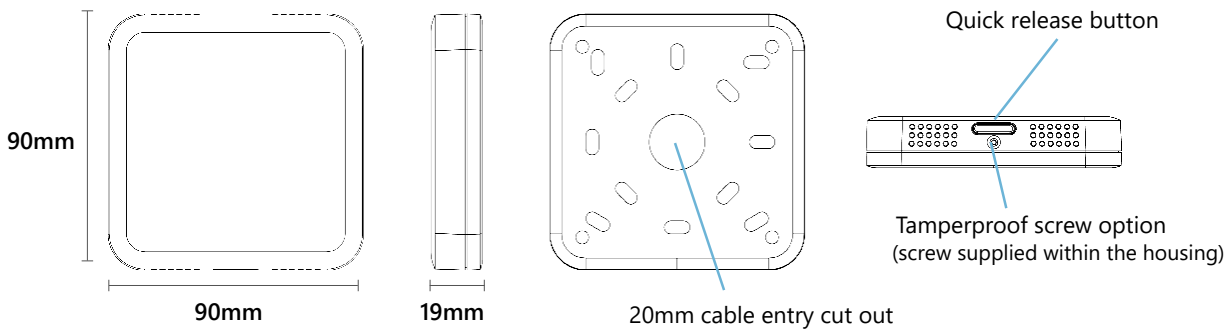

### Mounting Options

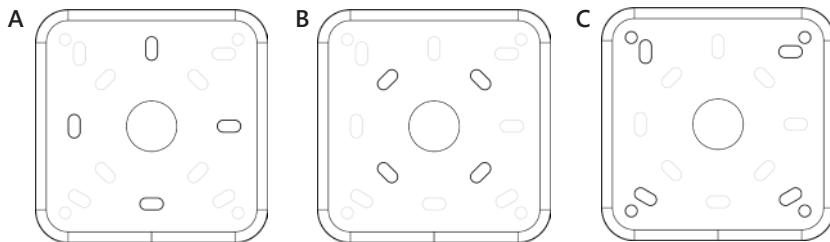

Option:	Mounting type:	Screw required:
A	Standard UK back box	M3.5 countersunk screw
B	Standard European back box	M3.5 countersunk screw
C	Direct to wall (no back box)	No. 6 (3.5mm counter-sunk wood screw)

## INSTALLATION AND MAINTENANCE

- The sensor must be installed by a competent and suitably qualified person and maintained within its stated operating environment
- The room sensor should be mounted in the space at approximately 1.5m from floor level.
- Mount away from the effects of direct sunlight, radiators and supply air ducts.
- Sensor cables should be segregated from any mains carrying conductors and electrical noise emitting equipment such as fluorescent lighting.
- Ensure correct screw sizes are used.
- Sensors should be installed after the space has been plastered, decorated and any flooring fitted.
- Do not spray any liquid or cleaning products directly onto the ventilated housing.
- Do not obstruct air flow vents.
- **Do not** blow directly on to the CO2 cell within the sensor, this can damage the cell membrane and could cause incorrect readings.

For further install and setup information please contact [technical@titanproducts.com](mailto:technical@titanproducts.com)