



TEMPERATURE & HUMIDITY SENSORS

TP-RS-RHT FEATURES

- Modern, slimline design
- 2% humidity accuracy
- Polygiene® anti-microbial product protection
- Quick and simple installation

Featuring a sleek, modern and slimline design, the TP-RS-RHT Gen 3 humidity and temperature sensor is designed to measure internal relative humidity and temperature conditions. The sensor is available with 4-20mA loop powered or 0-10V outputs for humidity and temperature. The sensor incorporates a second 10K3 thermistor temperature output with other resistive outputs available on request.

Quick release button, tamperproof features and pluggable terminals aid the install process and maintenance of the sensors.

All room housings within the Gen 3 product line incorporate certified Polygiene® product protection, designed to pro-actively inhibit the growth of bacteria on the sensor surface.

SPECIFICATION



Material:	ABS (Flame retardant)
Supply:	0-10V: 24VAC/DC +/- 10% 4-20mA: 4-20mA Loop Powered
Power Consumption:	0-10V: 45mA 4-20mA: 20mA max
Outputs: <i>TP-RS-RHT-V-10K3:</i>	0-10V (0-100%RH) 0-10V (0-50°C) 10K3A1 Resistive
Outputs: <i>TP-RS-RHT-MA-10K3:</i>	4-20mA loop powered (0-100%RH) 4-20mA loop powered (0-50°C) 10K3A1 Resistive
Accuracy:	Humidity: +/- 2%RH Temperature: +/- 0.2°C
IP Protection:	IP30
Mounting Location:	Wall mounted 1.5m from floor level
Environmental Conditions:	-10 to +60°C 0-95% RH Non-Condensing
Connections:	Pluggable screw terminals for 0.3 to 1.5mm cable
Recommended Cable:	Screened, twin twisted pair 0.75mm to 1mm. Screen earthed at controller end only.
Country of Origin:	UK
Product Codes:	0-10V: TP-RS-RHT-V-10K3 4-20mA: TP-RS-RHT-MA-10K3

CONNECTIONS

If only humidity monitoring is required there is no need to wire into the temperature terminals

TP-RS-RHT-V-10K3

0-10V Humidity, 0-10V Temperature with 10K3 Temperature

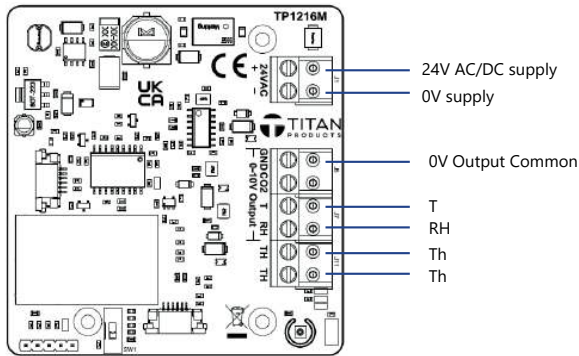

TP-RS-RHT-MA-10K3

4-20mA Humidity, 4-20mA Temperature with 10K3 Temperature

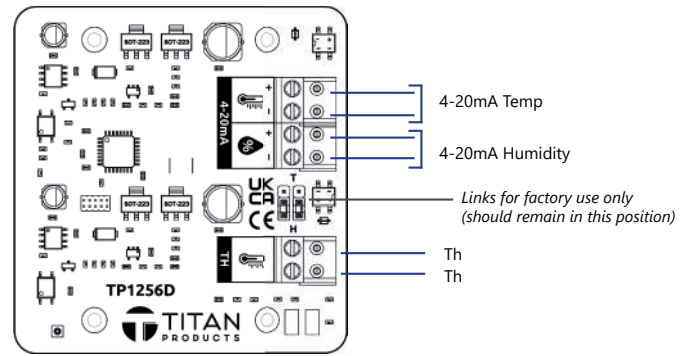

DIMENSIONS

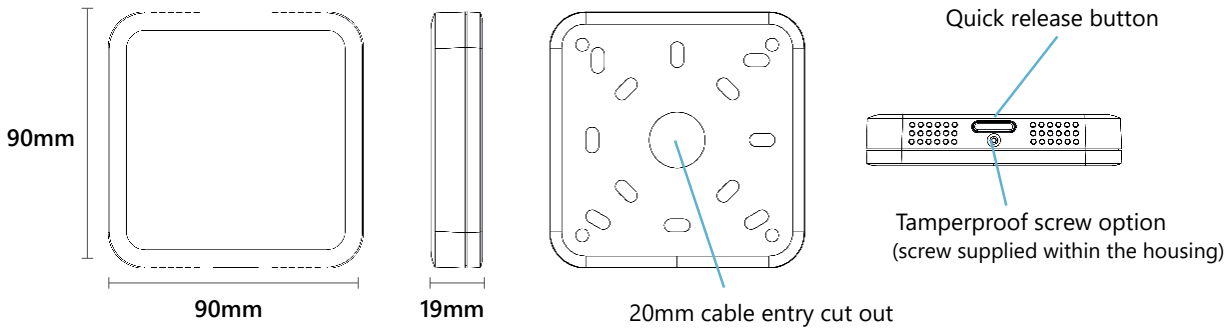

Mounting Options

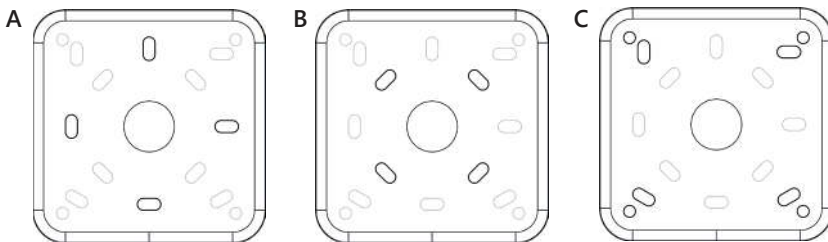

Option:	Mounting type:	Screw required:
A	Standard UK back box	M3.5 countersunk screw
B	Standard European back box	M3.5 countersunk screw
C	Direct to wall (no back box)	No. 6 (3.5mm counter-sunk wood screw)

INSTALLATION AND MAINTENANCE

- The sensor must be installed by a competent and suitably qualified person and maintained within its stated operating environment
- The room sensor should be mounted in the space at approximately 1.5m from floor level.
- Mount away from the effects of direct sunlight, radiators and supply air ducts.
- Sensor cables should be segregated from any mains carrying conductors and electrical noise emitting equipment such as fluorescent lighting.
- Ensure correct screw sizes are used.
- Sensors should be installed after the space has been plastered, decorated and any flooring fitted.
- Do not spray any liquid or cleaning products directly onto the ventilated housing.
- Do not obstruct air flow vents.

For further install and setup information please contact technical@titanproducts.com