



## Flexible Fan Coil & Underfloor Heating Control

### FCU-503 FEATURES

- Multiple heat / cool options for FCU and UFH applications
- Native BACnet communications
- Built-in control options for commercial and residential applications
- Fully compatible with the RDU-Touch user interface

Designed to provide complete heating and cooling control to a space or zone, the FCU-503 can be set up to provide control for the below applications:

- Fan Coil Heat / Cool.
- Fan Coil Cooling with Underfloor heating.
- Fan Coil Cooling with Underfloor heating and a second stage of Fan Coil heating.

Flexible control options allow the FCU-503 controller to be used in either commercial or residential applications.

The FCU-503 provides outputs for heating, cooling and fan control and is provided with options for fabric protection, set back, floor protection and water flushing / valve exercise routines as standard.

The FCU-503 can be used as a stand-alone controller, part of the Titan Products control solutions or part of a 3rd party BACnet network.

### SPECIFICATION

Power Supply	24V AC/DC +/-10%
Power Consumption	400mA excludes outputs @ 24V (includes 1x RDU)
Inputs/Outputs	4 x Digital Outputs 2 x Analogue Outputs 2 x Relay Outputs 2 x Digital/0-10V inputs 5 x 10K3A1 Temperature Inputs 1 x RDU Temperature Sensor
24VAC Digital Outputs	350mA max
0-10V Analogue Outputs	5mA max
Relay Outputs	Relays rated 3A at 24VAC max
Temperature Inputs	10K3A1
Communications	BACnet MS/TP (RS485)
Indication	Tx/Rx
Operating Temperature	5 – 40°C
Operating Humidity	20 – 80% RH Non-condensing
IP Rating	IP20
Mounting	DIN Rail
Dimensions	106 (w) x 92 (h) x 62 (d) mm
Country of Origin	UK
Product Code	FCU-503



## DIMENSIONS

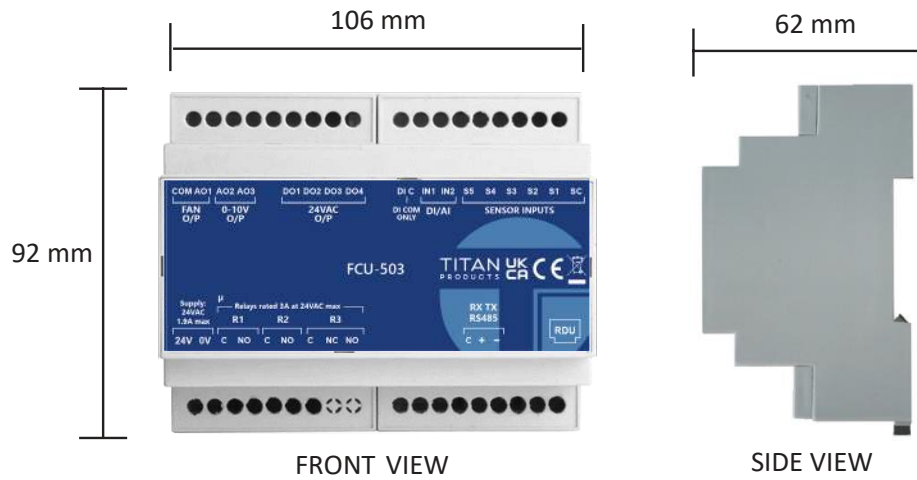

## CONTROLLER TERMINAL LAYOUT

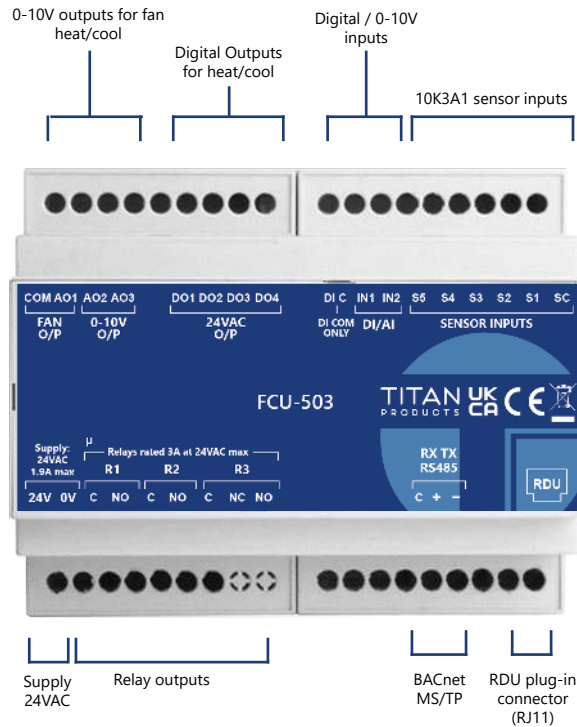

## FCU-503 CONTROLLER SETTINGS

The settings listed describe a range of the standard settings, options and operational features that are available from the applications library. All settings can be accessed and modified through the RDU-Touch or over the BACnet communications interface.

### Network Settings

Network	Native MS/TP BACnet (1/4 load) or Stand-alone.
Unit address	The controller's unique unit MAC address for BACnet MS/TP communications. Shown within the Unit Specific menu. <b>Range 1 to 127 for a master.</b>
Device Object ID	The controller's unique device object ID for BACnet MS/TP communications. The Device Object ID is unique for the whole of the site installation. Shown within the Unit Specific Menu. <b>Range 0 to 4194302</b>
Baud Rate	Set BACnet MS/TP communication baud rate. <b>Range: 9600, 19200, 38400 or 76800</b>
Group Control	Allows individual controllers to be set-up as a <b>Group Master or Group Slave</b> . Sets groups of slave controllers to take control information and instructions such as temperature, fan speed, ON/Off etc. from a common Master (126 Slaves max). Any number of Groups can be set within the limit of 127 controllers on the MS/TP network.

### Application Settings

Temp Units	Set °C or °F. All temperature units that are used in the controller setup menus and displayed in the user display menus will utilise the format selected.
Application Selection	Allows selection of the following application requirements: <b>Fan Coil Heat/Cool:</b> Sets the controller for a 4-pipe FCU heat / cool application. <b>Fan Coil Cool / UF Heat:</b> Sets the controller up for 2-pipe FCU cooling with under floor heating (UFH) control. <b>Fan Coil Cool/UF Heat/Fan Coil Heat Boost:</b> Sets the controller up for 4-pipe FCU heat / cool with UFH. Heating is two-stage, with UFH acting as the first stage and FCU heat as the second boost stage.
Time Scheduling	Enables the in-built 7-day calendar time clock within the controller.
Temp/Setpoint Display	When the Controller is connected to remote room display unit (RDU-Touch), this setting determines if the actual measured temperature is displayed or not.

The FCU-503 can control two zones within a residential application. Zone 1 is the main heating and cooling zone while Zone 2 utilises an independently controlled heating output designed for areas such as hallways and bathrooms where no FCU is installed.

### Zone 1 Heat / Cool Control settings:

Set point Bias	Bias the set point within the dead band to either the centre, heating edge or cooling edge.
Dead Band Setting	Sets the dead band between the heating and cooling control cycles.
Proportional Band Heat	Sets the proportional band for the heating cycle.
Proportional Band Heat Boost	Sets the proportional band for the heating boost cycle (if used).
Proportional Band Cool	Sets the proportional band for the cooling cycle.
Integral Time	Defines the Integral action time for the P+I control function.

Max Setpoint	Defines the maximum setpoint value the user can select.
Min Setpoint	Defines the minimum setpoint value the user can select.
Default Setpoint	Defines the control setpoint on power up or switch on.
Setback Setpoint	Defines the setback set point when the controller is operating to an occupied OFF state.
Low Limit Setpoint	Prevent cold draughts in the space when the unit is operating in a cooling mode. The control action will reduce the cooling output in a proportional manner prior to the low limit setpoint value being reached. If this value is reached the cooling output will be reduced to zero. Two settings are provided for this function; a setpoint and a low limit proportional band.
High Limit Setpoint	Prevent excessive temperatures within the supply air or underfloor heating from overheating when the controller is operating in a heating mode. The control action will reduce the heating output in a proportional manner prior to the high limit setpoint value being reached. If this value is reached the heating output will be reduced to zero. Two settings are provided for this function; a setpoint and a high limit proportional band.  Note: - Low / High limit control can be assigned to the temperature sensor S1, S2, S3, S4, S5, or one of the 0-10V analogue inputs.
Temperature Offset Value	Allows a positive or negative temperature offset to be applied to the measured control temperature.
System Flush	The system flush is designed to prevent water stagnating in the heating / cooling coils.  The FCU- 503 offers a system flush routine which can be programmed within the FCU-503 controller with an elapse run time, or enabled over BACnet communications from a Titan NetMaster or BMS.  The System Flush can be instructed to operate on the heat, cool or both valves.
Auto Flush	The period between flushes from a power cycle. Not Used when NetMaster or BMS System Flush Period Timer is used to enable the system flush routine.
System Flush Time	The period each valve is opened for during system flush.
System Flush BMS	Initiate the system flush via a BMS by writing to the relevant BACnet point (see BACnet manual). Note: The fan does not run in any Flush period.

## Zone 2 Control settings:

The FCU-503 offers a completely independent second heating output. This output will be controlled from the zones own settings set within the FCU-503. The second zone of control is designed for adjacent spaces to the main control zone such as bathrooms, hallways and corridors where ON/OFF heating control is required.

Once enabled, the following settings can be set for the second zone of independent heat control:

- Default set point
- Max set point
- Min set point
- Setback set point
- Temperature control input
- Limit control set point

Towel rail control:  
*(Residential applications)*

When the second zone is enabled, the option to provide towel rail control from a triac output is provided. The towel rail can operate to its own time schedule when used in conjunction with the Titan TP-CCS-7 user interface.  
Note: the bathroom and towel rail will be presented as separate zones within the user interfaces.

## Fan settings:

The FCU-503 supports 0-10V Fan Speed control used for EC fans.

Fan Speeds	Set the number (1-3) of manual fan speeds required across the 0-10V fan output.
Auto Fan Speed	Adds auto fan as an option to the user. Auto fan automatically increases/decreases the variable speeds on the 0-10V fan control output dependent on the temperature deviation from the controller set point.
Auto Fan Off in Db	Option to have the fan running through the dead band or stop the fan when the space temperature is satisfied.
Default Fan Speed Heat / Cool	Defines the default fan speed during the heat / cool cycles.
MAX Fan Output	The maximum voltage of the fan output.
MIN Fan Output (Heat)	The minimum voltage output of the fan during the heating cycle.
MIN Fan Output (Cool)	The minimum voltage output of the fan during the cooling cycle.
Fan Offset (Heat)	The fan PB start point before (+) or after (-) the start point of the heat valve opening. Allows the fan control to lead or lag the valve control.
Fan Offset (Cool)	This is the fan PB start point before (+) or after (-) the start point of the cool valve opening. Allows the fan control to lead or lag the valve control.
Fan PB (Heat)	Fan proportional band during the heat cycle.
Fan PB (Cool)	Fan proportional band during the cool cycle.
Fan Enable	Allows the use of one of the three on board relays to switch power to the fan when required.
Fan Start Up	Start the fan at full speed whenever switched ON from an OFF condition. The fan will receive full power for 10 seconds on startup before reducing to the selected default value.
Fan Overrun	Fan overrun time after any switch-off.
Fan ON Delay setting	Delay the start of the fan when the controller is enabled from an OFF condition to prevent the possibility of cold draughts when thermal actuators are being used. The delay will only run in the heating cycle.

## Valve and Control Settings

0-10V Valve Control Outputs 0-10V Analogue output 2 (AO2) and analogue output 3 (AO3) can be configured to control the heating and/or cooling valves:

**Dual Output:** 2 x 0-10V for individual control of heating and cooling.

**Single Output (1):** heating and cooling are single 0-10V signals with 5V acting as the balance setpoint. The heating has a span of 5 - 10V and the cooling has a span of 5 - 0V.

**Single Output (2):** heating and cooling are single 0-10V output depending on the heat / cool mode of the controller.

**MIN/MAX V Settings:** Both the Heat and Cool 0-10V outputs can be assigned individual MIN and MAX voltage settings. The Heat and Cool proportional bands will automatically re-scale dependent on the MIN and MAX voltage settings.

24VAC Valve Control Outputs The 4 x triac 24V AC outputs, DO1, DO2, DO3 & DO4, can be configured to control the heating and/or cooling valves. Control action options include PWM, TPC (Raise/Lower) or ON/OFF 24VAC control:

**PWM Pulse width modulation:**

- 1 x triac output to provide control of heating valve.
- 1 x triac output to provide control of cooling valve.

**TPC Time proportional control:**

- 2 x triac outputs to provide raise / lower positional control of heating valves.
- 2 x triac outputs to provide raise / lower positional control of cooling valves.

**On/Off control:**

- 1 x triac output to provide control of heating valve.
- 1 x triac output to provide control of cooling valve.

When not used for heat or cool valve control, any Triac 24V AC switched output can be configured to switch auxiliary/associated plant.

**PWM Control (24VAC)**

The PWM time operates on a mark/space ratio that is determined by the temperature deviation from the set point across the proportional band setting. PWM control is fully on when the temperature is outside the PB setting.

The temperature input resolution is 0.1°C therefore the incremental adjustment due to temperature change is stated as 10 per 1°C. The PWM time in seconds will be determined by the Proportional Band (Pb) setting.

If PWM control is selected, the controller provides an option to select an Intermittent Pre- Heat time for use with thermal actuators to keep inactive thermal actuators warm to achieve a close level of control.

**TPC Control (24V AC)**

Time Proportional Control (TPC) is utilized for 24VAC Open and Close (Raise / Lower) actuators. The setting should match the full run time of the actuator from fully closed to fully open. When TPC is used, the controller has the option to automatically synchronise the position of the actuators on switch OFF and every 24 hours on a continuously running system.

**On/Off Control (24V AC)**

For ON/OFF control of the heating and or cooling valves the proportional band setting equals the On/Off switching.

The Dead band setting represents the temperature value between the OFF point (heat or cool) and the switch ON point (cool or heat).

**Heat Enable**

Allows the use of one of the 3 on board relays, or any unallocated triac output, to enable/disable the heat source when required. The heat enable is triggered when the measured temperature falls into a heat cycle. Some applications may require a delay on enable whilst the heating valve opens to relieve back pressure on the circulating pump.

**Cool Enable**

Allows the use of one of the 3 on board relays, or any unallocated triac output, to enable/disable the cool source when required. The cool enable is triggered when the measured temperature increases into a cool cycle. Some applications require a delay on enable whilst the cooling valve opens to relieve back pressure on the circulating pump.

**Condensate Pump Enable**

Allows the use of one of the 3 on board relays, or any unallocated triac output, to activate a condensate pump if one of the FCU-503 digital inputs is allocated to condensate input and activated. Alternatively, the output can be set to run on an intermittent time base whenever the FCU cooling valve is active.

**Unoccupied Settings & Options**

Define the action to be taken when the controller is switched OFF:

Off Heat, cool and fan outputs off (0V). No low / high temp protection.

**Low Temp (Frost) Protection**

Allows for a minimum low temperature frost protection operation. Should the measured temperature fall to the low temperature set point then the controller and any associated plant is enabled. The fan will run at the default low fan speed with the heating valve opening to its min %. Should the temperature continue to fall the fan and valve will modulate to 100% across the Low Temp Protection proportional band. As the temperature increases the fan speed and valve will modulate down to Min % value and remain there until the measured temperature rises 1.5°C above the Low Temperature SP.

High Temp (Overheat) Protection Allows for a high temperature overheat protection operation. Should the measured temperature increase to the high temperature set point then the controller and any associated plant is enabled. The fan will run at the default low fan speed with the cooling valve opening to its min %. Should the temperature continue to increase then the fan and valve will modulate to 100% across the High Temp Protection proportional band. As the temperature decreases the fan speed and valve will modulate down to Min % value and remain there until the measured temperature decreases by 1.5°C below the High Limit Temperature SP.

## Inputs & Outputs (I/O)

Analogue or Digital Inputs 2 x inputs, In1 & In2, can be configured as either analogue (0-10V) inputs or digital volt- free switched inputs.

Analogue Inputs When configured as 0-10V analogue inputs each input can be configured for the following functions:

- Set Point adjustment with a variable range selectable from +/-2°C to +/- 10°C with 5V = to 0°C of adjustment.
- Monitoring: Any input can be used for remote BMS monitoring of 0-10V or Digital Inputs status conditions.

Digital Inputs When configured as digital inputs the volt-free switched contacts can operate on open or closed contacts:

- Remote ON/OFF
- Window Interlock
- Summer/Winter changeover
- Fan Proving
- Condensate Detection
- Occupancy Extension
- System Flush enable
- High Temperature Cut Out
- Fire Detection
- Status Monitoring

Temperature sensor Inputs 5 x 10K3A1 Temp sensor inputs (S1, S2, S3, S4 & S5) can be allocated to:

- Control sensor with averaging options.
- Limit sensor (supply air).
- External sensor.
- Resistive remote set point adjuster (1-11k).

0-10V Analogue Outputs 0-10V outputs can be configured to provide the following control options:

- Fan control.
- Heating valve control.
- Cooling valve control.
- Single output control of both heating and cooling valve.
- Summer/Winter heating or cooling changeover control from 1 x 0-10V output.
- 0-10V On/Off valve control.

Triac 24V AC Outputs 24VAC digital outputs can be configured to provide the following control options:

- Heating valve control (PWM, TPC or On/Off)
- Cooling valve control (PWM, TPC or On/Off)
- Second zone heating control.
- Bathroom towel rail control.
- Heat/Cool enable.
- Fan enable.
- System fault indication

On-board Relays 2 x NO contact and 1 x changeover relays can be configured to operate under the following options:

- Auxiliary Plant – Used to start up common circuits such as enabling under floor heating wiring centres, heating and cooling sources on demand.
- Fan Enable – Used to switch power to the fan when required.

## CABLE RECOMMENDATIONS

Item	Cable Spec & Reference	Requirements
BACnet Communications to BMS Router and between Master - Slave Controllers	Belden 9841 (0.2mm <sup>2</sup> ) Twisted Pair with Drain wire and foil wrap or equivalent.  <b>Note: Drain wire can be used to as a common connection.</b> <b>Note: Must be suitable for RS485 Standard</b>	Daisy chain network configuration only. The cable shield must be connected to Earth ground at the network router end only. <b>Note: Ensure a 120 ohms resistor is fitted to end of line controller.</b>
Plug In lead between FCU503 & RDU-Touch	RJ45 CAT5 cable (unbooted recommended) <b>Note: Titan Products can supply premade leads to length</b>	Max Cable length 100m Straight-Through cable type.
Resistive 2 Wire Temperature Sensors	2 Core twin twisted screened:- 0.75mm -1mm Belden 8760 (0.82mm <sup>2</sup> ) or Equivalent	Screen Earthed at Controller end only
0-10V Sensors	2 Core twin twisted screened:- 0.75mm -1mm Belden 8760 (0.82mm <sup>2</sup> ) or Equivalent	Screen Earthed at Controller end only
Valve and Damper Actuators	4 Core Screened:- 2 x Twisted Pair:- 0.75mm -1mm Belden (0.82mm <sup>2</sup> ) or Equivalent <b>Note: This depends on the type and number of actuators being used. Check requirements with actuator manufacturer before installation</b>	Screen Earthed at Controller end only
Digital inputs :- PIR's / Condense Sensor / Fan prove/ On-Off Switch	2 Core twin twisted screened:- 0.75mm -1mm Belden 8760 (0.82mm <sup>2</sup> ) or Equivalent	Screen Earthed at Controller end only

- All low voltage cables must be segregated from any mains carrying inductors and they should not be run in the same containment system
- All low voltage cables must not run in close proximity to any mains AC inductive loads such as florescent fittings and electric motors

### BACnet Network Configuration

Based on the standards for RS485 networks a BACnet MS/TP network layer allows for only a daisy-chained network configuration, consisting of a single cable routed between controllers. Star and Ring network topologies are not supported.

The network electrically supports a maximum of 127 nodes, however BUS network size capability is determined by factors such as network traffic and BMS capabilities and we recommend maximum network size of 32 devices.

To comply with the EIA-485 standard, the maximum number of nodes per segment shall be 32 and any additional nodes will require the use of repeaters. If only Titan controllers are on the MS/TP network, the number of controllers may be increased but this will depend on the network traffic, the baud rate being used and the length/route of the cable.

A termination resistor of 120 ohms should be connected at each of the end devices, when a network is connected to a Router or BMS this becomes one of the end devices. Please check with the Router/BMS manufacturer if the 120 ohms end of line resistor is fitted internally.



## BACNET CONNECTIONS

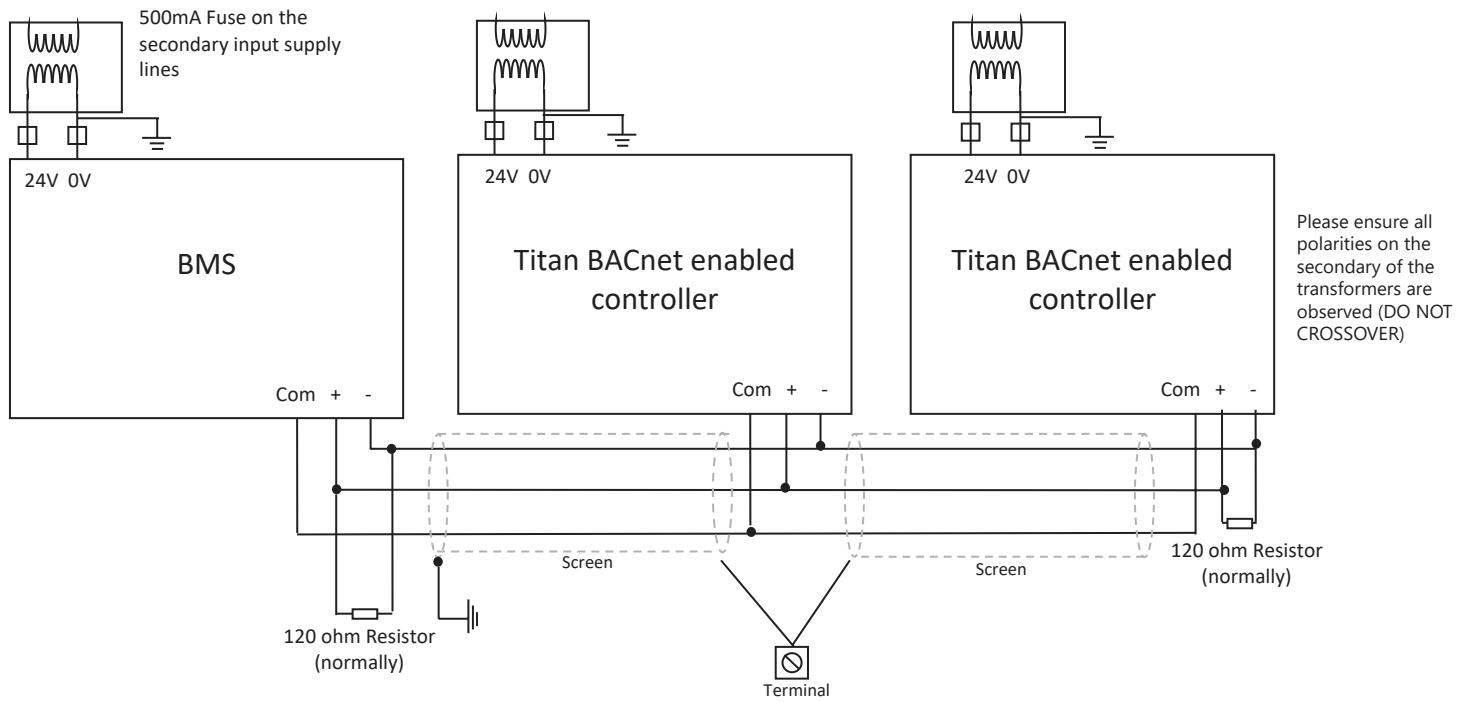

The above diagram shows a typical 3-wire daisy chain configuration. For all BACnet standard wiring variants please consult ASHRAE wiring standards.