



WINDOW ACTUATOR POSITIONING MODULES

IO/AD3W FEATURES

- Converts 0-10V to 24VDC
- 3 different timing models available
- 3 x forward/reverse motor control outputs (each 5 amp max, combined max must not exceed a total of 9 amps)

The IO/AD3W Window Positioning Unit is designed to provide an interface between 0-10V control signals from the BMS to the 24V DC motors driving the natural ventilation actuators on louvers, windows and blinds to the desired position.

The unit provides three separate bi-directional output drives which can be controlled from three 0-10V input signals. This is achieved through 6 x 5A relays arranged in pairs.

Each drive is individually fused at 5A with a self resetting fuse and all drive outputs are supplied from two terminals to which an independent 24V DC supply should be connected.

Each output has red and green LEDs to indicate relay status (off, opening, closing)

The supply to the unit logic is independent of the above and is 24V AC/DC. The 3 x 0-10V inputs are referenced to this supply.

SPECIFICATION

Power Supply:	24V AC/DC +/-10% 24V DC supply for motor control
Inputs:	3 x 0-10V input control signals (20K impedance)
Outputs:	3 x Forward/Reverse motor control outputs (5 amp max) *see synchronisation statement
Power Consumption:	60mA max
Operating Temperature:	0 to 50°C
Operating Humidity:	5-80% non-condensing
Dimensions:	113mm high, 82mm wide, 45mm deep
Mounting:	DIN Rail
Country of Origin:	UK
Product Codes:	IO/AD3W/5-75 IO/AD3W/20-100 IO/AD3W/30-110



Synchronisation

Important: On power up all 3 drive close relays will automatically be driven in unison for synchronisation of the window positioning to a closed position. The maximum overall current load through this module **must not exceed 9 amps.**

OUTPUT CONTROL

The output control is time proportional to the motor maximum drive time and the level of the 0 to 10V input signal for a given channel, for example a 50% position requires an input signal of 5V to be maintained. The maximum drive time must be set at commissioning after timing the actual drive time of the actuator. The actuator time setting is done by a three way binary coded DIP switch allowing the base time to be selected and a finger turn potentiometer to give an additional 10 secs of adjustment. The actuator run time settings are shown in the following table:

IO/AD3W/20-100

SW1	SW2	SW3	Base time	Pot Adjustment
Off	Off	Off	20 secs	20 to 30 secs
On	Off	Off	30 secs	30 to 40 secs
Off	On	Off	40 secs	40 to 50 secs
On	On	Off	50 secs	50 to 60 secs
Off	Off	On	60 secs	60 to 70 secs
On	Off	On	70 secs	70 to 80 secs
Off	On	On	80 secs	80 to 90 secs
On	On	On	90 secs	90 to 100 secs

IO/AD3W/30-110

SW1	SW2	SW3	Base time	Pot Adjustment
Off	Off	Off	30 secs	30 to 40 secs
On	Off	Off	40 secs	40 to 50 secs
Off	On	Off	50 secs	50 to 60 secs
On	On	Off	60 secs	60 to 70 secs
Off	Off	On	70 secs	70 to 80 secs
On	Off	On	80 secs	80 to 90 secs
Off	On	On	90 secs	90 to 100 secs
On	On	On	100 secs	100 to 110 secs

IO/AD3W/5-75

SW1	SW2	SW3	Base time	Pot Adjustment
Off	Off	Off	5 secs	5 to 15 secs
On	Off	Off	15 secs	15 to 25 secs
Off	On	Off	25 secs	25 to 35 secs
On	On	Off	35 secs	35 to 45 secs
Off	Off	On	45 secs	45 to 55 secs
On	Off	On	55 secs	55 to 65 secs
Off	On	On	65 secs	65 to 75 secs
On	On	On	75 secs	75 to 85 secs

SW4 is not used in this application.

On power up the module drives all outputs to the fully closed position for the time period set on the switches and the pot plus 20%, this is to synchronise the module and ensure that the actuators are at the fully closed position. After this initial power up condition the synchronisation will be carried out automatically each time the actuators are driven to the fully closed position, this is done by driving the close signal for an additional 20% of the drive time, while this is being carried out the analogue input signal is ignored.

If desired the 0 to 10V inputs can be looped on the terminals to provide simultaneous drive to all three outputs. The input impedance of the 0-10V signals is 20K which gives 0.5 mA current drain per input with a 10V signal.

When using Time bases less than 10 seconds it is recommended that the control signal is set to give "Fixed Position" control from "Fixed Voltage" values. Modulating control signals at this low time based can cause poor positional control which can result in loss of synchronisation.

CONNECTIONS

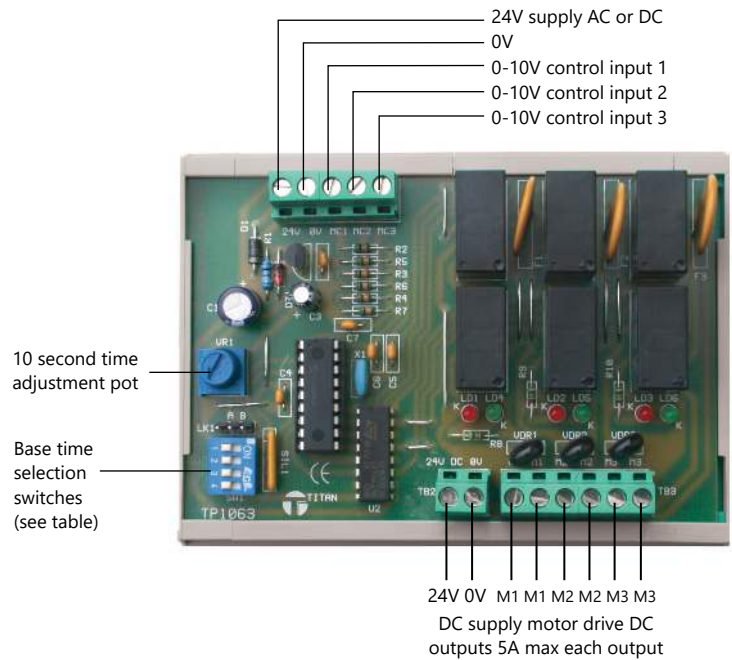

For further install and setup information please contact technical@titanproducts.com