



## 2 STAGE CONTROL

### IO/2RM FEATURES

- Raise/Lower, Hi/Low or Binary selectable outputs
- Time Proportional Control output
- Converts 0-10 or 2-10V input to relay control

The IO/2RM is designed to convert a selectable 0-10V or 2-10V control signal to digital relay switching. The IO/2RM offers four selectable control options: Raise/Lower, Hi/Low, Binary and a Time Proportional Control (TPC) output.

A potentiometer setting is available to provide a delay ON time before the relays are energised and each relay has a selectable Auto/Manual/Off selector switch with LED status indication.

The IO/2RM is designed to offer control of motorised valves, damper actuators, step controllers and pump changeover and is compatible with most BMS controllers.

### SPECIFICATION

Power Supply:	24V AC/DC +/-10%
Input (Signal):	0-10 or 2-10V (load 0.5mA max)
Output Contacts:	2 x volt free 5A at 240V AC (inductive)
Power Consumption:	55mA
LED Indication:	When relay energised
Terminals:	1.0mm recommended 2.5mm max
Operating Temperature:	0 to 50°C
Operating Humidity:	5-80% non-condensing
Dimensions:	82mm high, 56mm wide, 42mm deep
Mounting:	DIN Rail
Country of Origin:	UK
Product Code:	IO/2RM



## CONNECTIONS

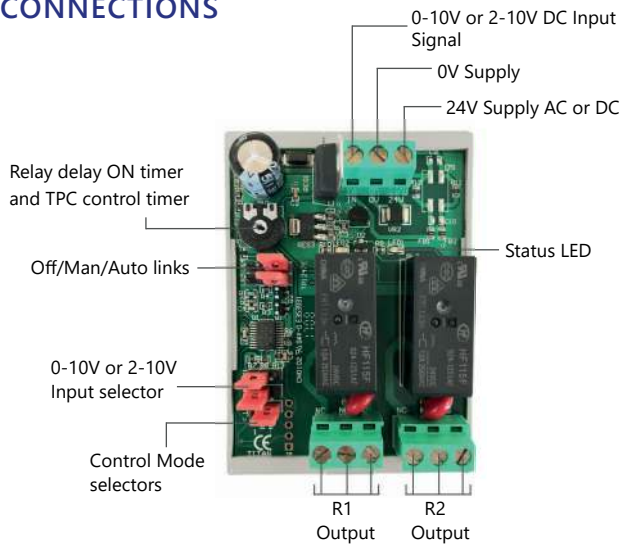

## SWITCHING VOLTAGES

Switching Voltages (V)	Input Voltage Tolerance	Raise/Lower		Binary		High/Low	
		R1	R2	R1	R2	R1	R2
0	<1.5V	Off	Off	Off	Off	Off	Off
3	1.5V < input > 4.5V	On	Off	On	Off	On	Off
6	4.5V < input > 7.5V	Off	Off	Off	On	On	Off
9	7.5V < input	Off	On	On	On	On	On

## LINK SELECTIONS FOR CONTROL MODE

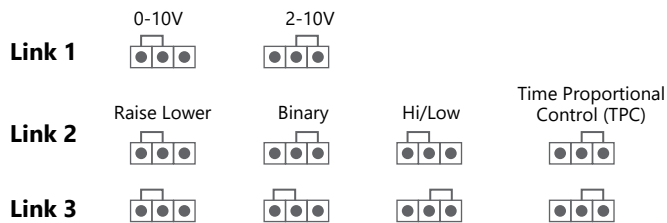

## TIMING POTENTIOMETER

### Timing Potentiometer (Range 0 to 100 seconds)

This pot is used to provide an adjustable ON time delay between relays in the Hi / Low (Sequence) and Binary modes.

## TPC CONTROL SYNCHRONISATION

### (Range 10 to 300 seconds - 10 seconds fully anti-clockwise, 300 seconds fully clockwise)

On power up of the module, RL1 is energised for a period equal to the time set on the potentiometer + 10% to ensure that the actuator motor is driven to the fully closed position before the TPC control action is established.

During operation the input control signal is sampled at 10 second intervals and if this is greater than 9.8V for a period of 10 times the time period set on the potentiometer then R2 will be energised for a period equal to 50% of the full drive period and the TPC control action will be set at maximum, ensuring the motor position and the control point are synchronised (fully open). Once the auto synchronisation is complete normal control is re-established.

A similar action is taken if the control input value is less than 0.2V (2.2V) over the same period except R1 is then energised for 50% of the full drive period, as set on the pot, and the internal counter is set to zero (fully closed).

The relay control action control action is directly proportional to the signal input but subject to the minimum input resolution and the minimum relay activation time (see below):

Example with Control input set for 0-10V and the potentiometer set at full 300 seconds:

- From a synchronised closed should the input be 5V then R2 will energise driving the open output for ½ the set time period (150 seconds). After the elapsed time then both relays are de-energised.
- Should the control input go to 2.5V then R1 will energise for ¼ of the set time period (75 seconds). After the elapsed time period both relays are de-energised.

- This control action continues proportionally to the changing input signal with a response to a change of 0.1V on the input signal dependant on the timer setting and the requirement for a minimum 2 second relay activation time (see below)
- To avoid continuous relay operation due to a fluctuating input signal, the signal must be stable for a minimum of (2 seconds) or the input measures the average signal value over (2 seconds).
- The output action for any relay operation must be a minimum of 2 seconds therefore the response resolution will change due to the setting of the timer pot and the control input range selected :

- |   |  |                            |
|---|--|----------------------------|
| - | 0-10V & Pot at 300 seconds: 0.1V input resolution    | = 3 second activation      |
| - | 0-10V & Pot at 150 seconds: 0.1334V input resolution | = 2 second activation time |
| - | 0-10V & Pot at 100 seconds: 0.2V input resolution    | = 2 second activation time |
| - | 2-10V & Pot at 300 seconds: 0.1V input resolution    | = 3.75 second activation   |
| - | 2-10V & Pot at 150 seconds: 0.1067V input resolution | = 2 second activation time |
| - | 2-10V & Pot at 100 seconds: 0.16V input resolution   | = 2 second activation time |

## RELAY WIRING FOR TPC OPERATION

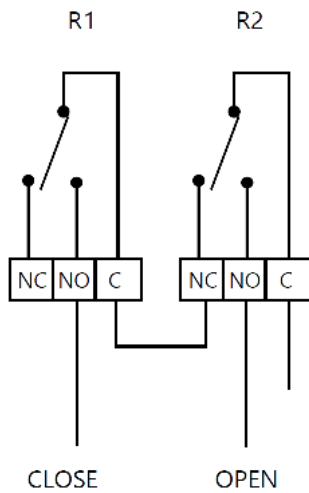

For further install and setup information please contact [technical@titanproducts.com](mailto:technical@titanproducts.com)