

DIGITAL INPUT MULTIPLEXER (DIM6-8)

IO/DIM6-8 FEATURES

- 6 or 8 Volt Free Digital Inputs
- Multiplexed 0-10V or 4-20mA output

The IO/DIM6-8 is designed to accept volt free digital inputs and convert the inputs to a multi-stage voltage (0-10V) or multi-stage milliamp (4-20mA) output.

The configuration of 6 or 8 inputs is link selectable. The IO/DIM6 input is binary providing 64 levels of output whilst the 8 input mode is a multiplexed signal of 2 x 4 inputs on a time base.

SPECIFICATION

Power Supply:	24V AC/DC +/-10%
Input:	6 or 8 x Volt free contacts
Output:	0-10V DC (o/p impedance > 100 ohms) 4-20mA (load 500 ohms)
Power Consumption:	Max 30mA + output load
LED Indication:	When input contact closed
Terminals:	1.0mm recommended 2.5mm max
Input Test:	Link Jumpers
Operating Temperature:	0 to 50°C
Operating Humidity:	5-80% non-condensing
Dimensions:	82mm high, 57 mm wide, 43mm deep
Mounting:	DIN Rail
Country of Origin:	UK
Product Code:	IO/DIM6-8



CONNECTIONS

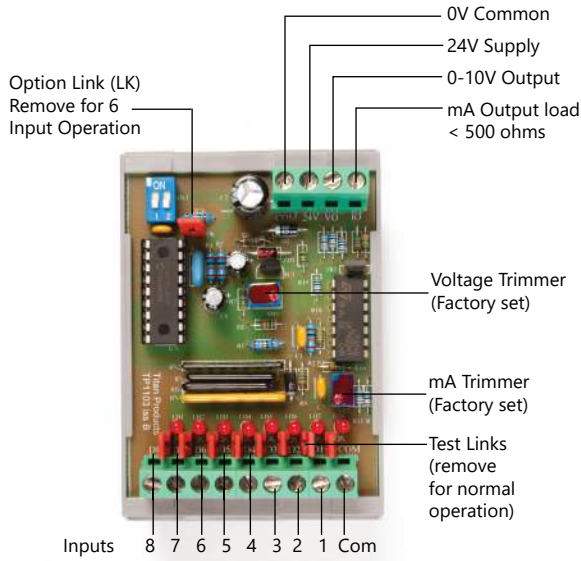

6 Input Operation (Link LK removed)

Input 1	Input 2	Input 3	Input 4	Input 5	Input 6
0.16V	0.31V	0.63V	1.25V	2.50V	5.00V
4.25mA	4.50mA	5.00mA	6.00mA	8.00mA	12.00mA

8 Input Operation (Link LK fitted)

Inputs	V value	mA value	Output Signal	Time (secs)
Start/Synchronisation	10V	20mA	10V or 20mA	4 secs
Input 1	0.6V	5.00	Binary Combined Value	4 secs
Input 2	1.2V	5.99		
Input 3	2.4V	7.98		
Input 4	4.8V	11.96		
Input 5	0.6V	5.00	Binary Combined Value	4 secs
Input 6	1.2V	5.99		
Input 7	2.4V	7.98		
Input 8	4.8V	11.96		
BACK TO START				

The IO/DIM6/8 output signal is transmitted in a time frame of 4 seconds for the inputs 1 to 4 and then 4 seconds for the inputs 5 to 8. The time frame sequence is synchronised by a 10V or 20mA signal as shown in the above table.

The IO/DIM6/8 mode is particularly useful for applications where BMS outstations have restrictive analogue input capability enabling 8 digital inputs to be converted to 1 analogue output.

IO/DIM6 Binary Output Table

Decimal Input	Input Count Binary	Output Voltage	Output Current (mA)
0	000000	0.00	4.00
1	000001	0.16	4.25
2	000010	0.31	4.50
3	000011	0.47	4.75
4	000100	0.63	5.00
5	000101	0.78	5.25
6	000110	0.94	5.50
7	000111	1.09	5.75
8	001000	1.25	6.00
9	001001	1.41	6.25
10	001010	1.56	6.50
11	001011	1.72	6.75
12	001100	1.88	7.00
13	001101	2.03	7.25
14	001110	2.19	7.50
15	001111	2.34	7.75
16	010000	2.50	8.00
17	010001	2.66	8.25
18	010010	2.81	8.50
19	010011	2.97	8.75
20	010100	3.13	9.00
21	010101	3.28	9.25
22	010110	3.44	9.50
23	010111	3.59	9.75
24	011000	3.75	10.00
25	011001	3.91	10.25
26	011010	4.06	10.50
27	011011	4.22	10.75
28	011100	4.38	11.00
29	011101	4.53	11.25
30	011110	4.69	11.50
31	011111	4.84	11.75
32	100000	5.00	12.00
33	100001	5.16	12.25
34	100010	5.31	12.50
35	100011	5.47	12.75
36	100100	5.63	13.00
37	100101	5.78	13.25
38	100110	5.94	13.50
39	100111	6.09	13.75
40	101000	6.25	14.00
41	101001	6.41	14.25
42	101010	6.56	14.50
43	101011	6.72	14.75
44	101100	6.88	15.00
45	101101	7.03	15.25
46	101110	7.19	15.50
47	101111	7.34	15.75
48	110000	7.50	16.00
49	110001	7.66	16.25
50	110010	7.81	16.50
51	110011	7.97	16.75
52	110100	8.13	17.00
53	110101	8.28	17.25
54	110110	8.44	17.50
55	110111	8.59	17.75
56	111000	8.75	18.00
57	111001	8.91	18.25
58	111010	9.06	18.50
59	111011	9.22	18.75
60	111100	9.38	19.00
61	111101	9.53	19.25
62	111110	9.69	19.50
63	111111	9.84	19.75

IO/DIM8 Output Table

Decimal Input	Binary Inputs				Output Voltage	Output Current (mA)
	1	2	3	4		
0	OFF	OFF	OFF	OFF	0	4.00
1	ON	OFF	OFF	OFF	0.6	5.00
2	OFF	ON	OFF	OFF	1.2	5.99
3	ON	ON	OFF	OFF	1.8	6.99
4	OFF	OFF	ON	OFF	2.4	7.98
5	ON	OFF	ON	OFF	3.0	8.97
6	OFF	ON	ON	OFF	3.6	9.96
7	ON	ON	ON	OFF	4.2	10.96
8	OFF	OFF	OFF	ON	4.8	11.96
9	ON	OFF	OFF	ON	5.4	12.95
10	OFF	ON	OFF	ON	6.0	13.94
11	ON	ON	OFF	ON	6.6	14.93
12	OFF	OFF	ON	ON	7.2	15.92
13	ON	OFF	ON	ON	7.8	16.91
14	OFF	ON	ON	ON	8.4	17.90
15	ON	ON	ON	ON	9.0	18.93

Voltage Output accuracy = +/- 2.5% of stated value
mA output accuracy = +/- 1% of stated value

The IO/DIM8 selection operates with a synchronisation 10V or 20mA Multiplexed Output for 4 seconds followed a second signal for 4 seconds illustrating the status of inputs D1-D4. A third signal for a further 4 seconds will illustrate the status of D5-D8 inputs.

After this the 10V or 20mA synchronisation signal with occur and the cycle repeats.

For further install and setup information please contact technical@titanproducts.com